



PRODUCT CATALOG & PRICE LIST

V. 003-007



AXINAR

Your Trusted Manufacturer

AXINAR is a rapidly growing company specializing in the production of innovative heating products. Established in 2010, our mission is to provide comprehensive, eco-friendly, and intelligent heating solutions for both industrial and residential purposes.

As a trusted partner, we design and manufacture high-quality heating products that meet the needs of even the most demanding clients. Simultaneously, we cultivate long-term relationships of trust with collaborators and suppliers, maintaining a high level of service.

The company continually expands its product range with a focus on continuous quality improvement, sustainable development, innovation integration, and adopting technological advancements. Our updated portfolio of heating system products includes:

- Biomass Boilers
- Burners
- Heating System Components
- AXINAR Academy Training/Maintenance Services

All our products are crafted from certified raw materials and top-quality components to ensure reliability. For this reason, we conduct rigorous quality control and select suppliers based on strict criteria. We possess fully customized production facilities for heating systems and the necessary expertise to manufacture both the final products and their operational software.

We appreciate your trust and remain committed to achieving even greater goals. Thank you!

Nikolaidis Giorgos (Mech. Engineer)
CEO & Founder
AXINAR Company

CONTENTS

PELLETWORK (Pellet Complete System) PAGE 3
PELLET BURNERS – APOPLIM/ TSOVEA PAGE 4
PELLET BOILLER- Pelit PAGE 5
EXTERNAL PELLET FEEDER- Auger PAGE 5
PELLET TANK- Abar PAGE 5
PELLET UNIT – Calos PAGE 6
WOOD BOILER – BM PAGE 7
WOOD BOILER- Peskon PAGE 8
PYROLINO PLUS PAGE 9
CABINET FOR GAS BOILER PAGE 10
Multi-Zone Heating Controller PAGE 12
SOLBOX PAGE 13
THERMOSTAT Axistat PAGE 14

PELLETWORK

20 - 150 KW SERIES

- Complete System
- Robust Modular design
- Ease of use
- Multiple Vertical flue gas paths
- AutoClean Standard boiler
- Analog burner
- Practical fuel storage tank



PELLETWORK	PW20	PW30	PW45	PW75	PW95	PW120	PW150
Power (kW)	20	30	45	75	95	120	150
Power (Kcal)	17.000	25.000	38.000	63.000	85.000	100.000	130.000

APOPLIM TSOVEA

20 – 45 KW

75 – 150 KW

- Analog Burner
- Ceramic Igniter (1200° C)
- High-grade non-magnetic stainless steel
- Internal auger
- User-friendly menu with only one button (translated up to 40 LGs)
- 5-step wizard for activation
- Large LCD screen
- Low-noise, multi-speed fan
- AutoClean by air
- AutoClean by sliding piston
- Auger included

✓	✓
✓	✓
✓	✓
✓	✓
✓	✓
✓	✓
✓	✓
✓	✓
✓	✓
✓	✓
✓	✓

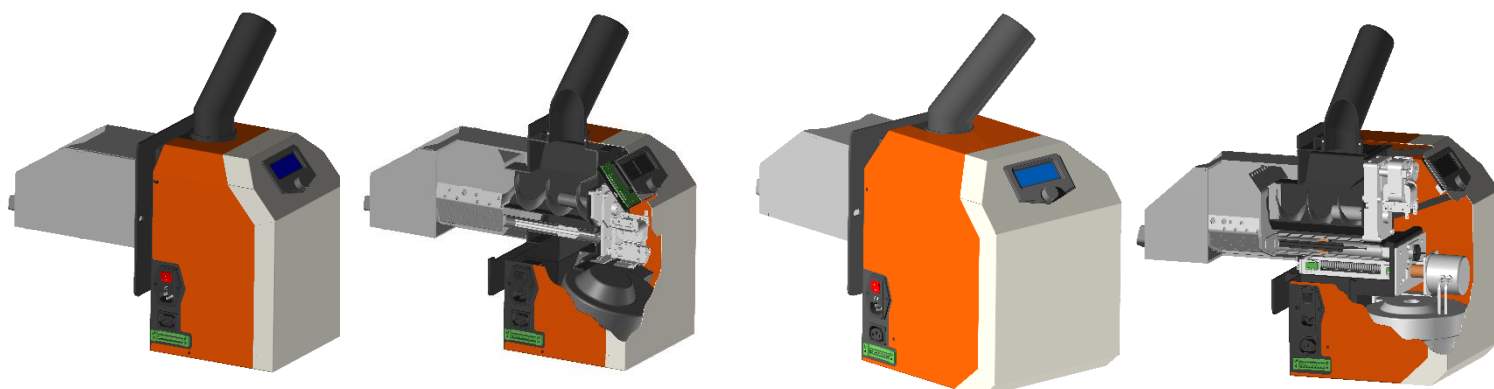

PLUG & PLAY

1. Mount it on the boiler
2. Connect power
3. Plug Feeder
4. Connect the hot water sensor



APOPLIM	AP20	AP30	AP45
Power (kW)	20	30	45

TSOVEA	TS75	TS95	TS120	TS150
Power (kW)	75	95	120	150

PELIT 20 - 150 KW SERIES

- Multiple Vertical flue gas paths
- Autoclean standard boiler
- Large ash tray
- Certified Steel (EN 10204)



PELIT	PL20	PL30	PL45	PL75	PL95	PL120	PL150
Power(kW)	20	30	45	75	95	120	150
Power (Kcal)	17.000	25.000	38.000	63.000	85.000	100.000	130.000

EXTERNAL PELLET FEEDER

AUGER

- Non-magnetic high-grade stainless steel
- Non-combustible 35cm polyurethane tube
- Ash-repellent material

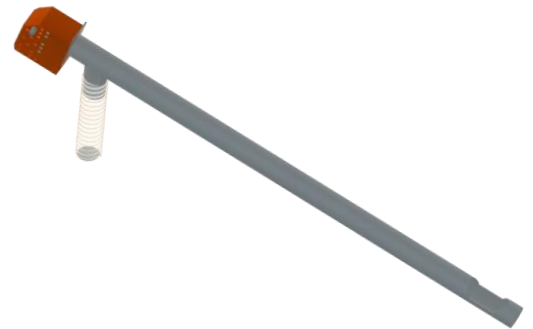

Power (kW)	Dimensions (mm)
Max 190kW	Φ63 x1,45m

ABAR

- Made out of steel sheet with electrostatic paint
- 360 degrees revolving feeding port
- Conical shape
- Easy transport
- Convenient packaging

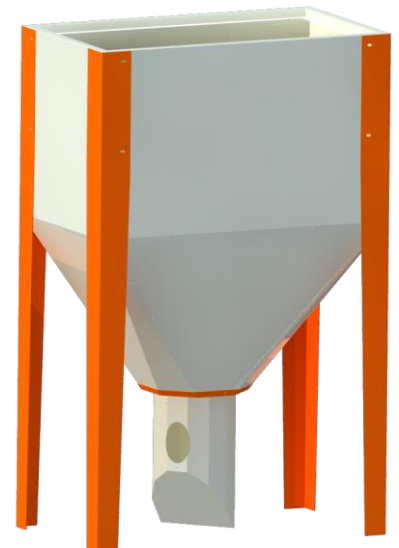

Capacity (L)	Capacity (kg)	Dimensions (cm)
310	200	48x94x120
1500	1100	

CALOS

8 – 32 KW SERIES

- All-in-one pellet unit
- Ready to use
- AutoClean Standard boiler
- Easy transport & installation

Includes a circulator, an expansion vessel, a safety valve, an automatic air vent and an automatic filling valve with pressure gauge

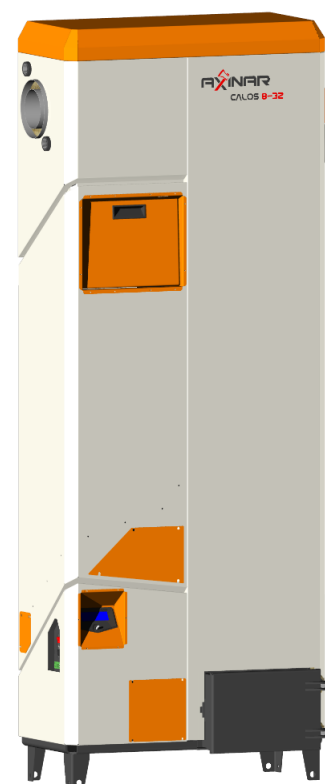

CALOS	CL8 - 32
Power (kW)	8 - 32
Power(Kcal)	6.900 – 27.500
Length (mm)	700
Width (mm)	350
Height (mm)	1900
Ashtray Capacity (L)	15

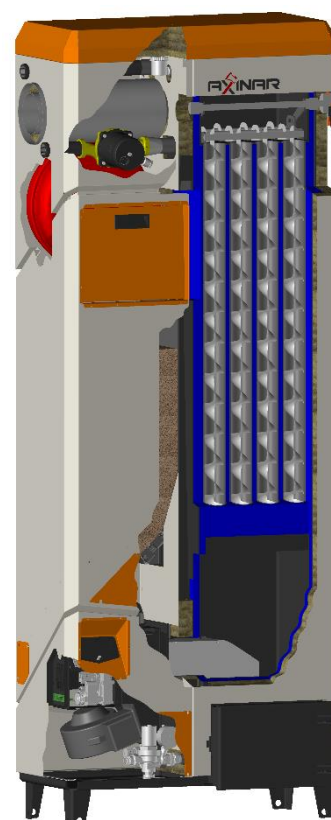

BM

30 – 60 KW SERIES

- Large refueling door
- Flue gas thermometer
- Double centrifugal fan
- Automatic Pyrolysis cleaning
- Patented magnetic damper
- Alternative heat source control
- Excess heating management system
- Anti-frost function
- 3 combustion modes
- thermostat controlled



	BM30	BM60
BM		
Power (kW)	30	60
Power (Kcal)	25.800	51.600

PESKON

30 - 60 KW SERIES

- Large refueling door
- Integrated heat exchanger



PESKON	PSK30	PSK60
Power (kW)	30	60
Power (Kcal)	25.800	51.600

Pyrolino Plus

- Pellet Patio Heater for outdoor and semi-outdoor spaces
- High thermal efficiency (14kW output covers up to 60sqm)
- Automatic cleaning, with the operator's minimum intervention
- Zero smoke/
Zero odors
- Non-blackening glass
- Pellet container for 5.5 hours of continuous burning
- Return on investment within 3 months of use (pellet: 30% cheaper than propane per kW!)



Power (kW)	14
Power (Kcal)	12.038

CABINET FOR GAS BOILERS

- Compatible with 74 gas boiler models
- 30mm stonewool insulation
- Electrostatic paint.
- Locking mechanism

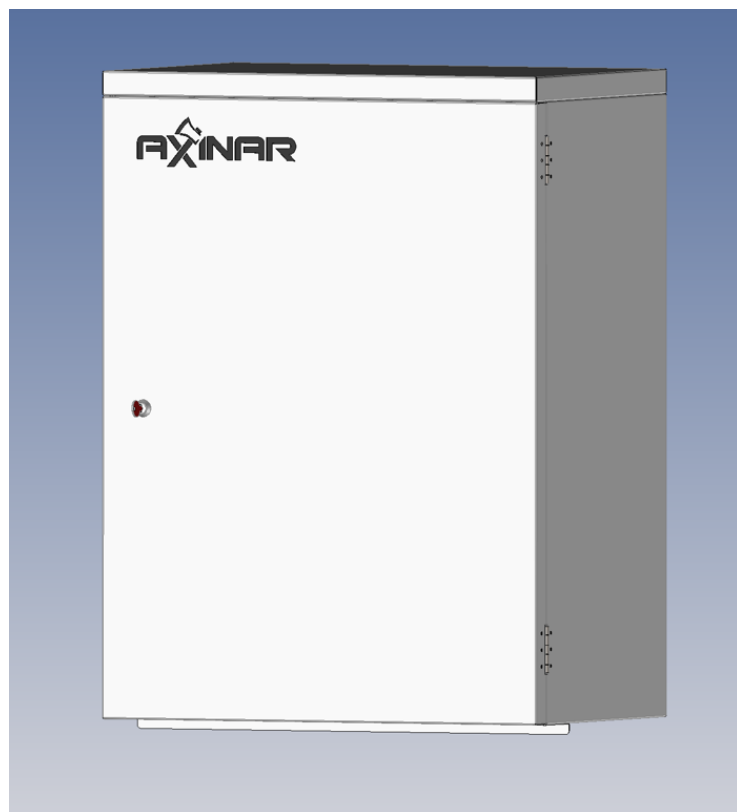

	JS1 small(1)	JS2 large(2)
DIMENSIONS (mm) WxDxH	620x400x841	620x445x950

BRAND	MODEL	KW	OPTION	BRAND	MODEL	KW	OPTION
BAXI				FEROLI			
	LUNA 3 COMFORT	24	1		BLUE HELIX	25	1
	LUNA 3/ STAR DIGIT	24	1		DIVA CONDENS	24/28	1
	QUASAR D	24	1	DE DIETRICH			
	MAIN/PULSAR D	24	1		ZENA	24	1
	LUNA 2000/ STAR CONDENS	24	1		ZENA PLUS	24/28/31	1
	LUNA 3 AVANT	24	1		MPX	24/33	1
	DUO-TEC COMPACT	24	1		VIVADENS	24/35	1
	PRIME	24	1	NITROMIX			
	LUNA EXT	24	1		P	24	1
					BS	24	1
IMMERGASS				RIELO			
	EOLO MINI/STAR (analog)	24	1		CALDARIELLO	24	1
	EOLO MINI (digital)	24	1		RESIDENCE	24	1
	EOLO MINI (digital)	28	1		RESIDENCE	28	1
	EOLO STAR 23	23	1	BUDERUS			
	MONO EOLO/ MYTHOS	24	1		LOGAMAX U02	24	2
	EOLO STAR 24	24	1		LOGAMAX	24	1
	MINI EOLO/MYTHOS	28	1		LOGAMAX GB012	24	1
	EOLO MAIOR	24/28/32	2		LOGAMAX GB062		2
	EOLO EXTRA	24/28/32	1	VAILANT			
	EOLO EXTRA HP	24/30	1		ECOTECH	24	1
	VICTRIX	24/26	1		TURBOTECH VUW	24	2
	VICTRIC SUPERIOR/TOP	32	2	WOLF			
	VICTRIC EXA	24/28	1		CGB-K-20	20	2
	VICTRIX TT	24	1		CGB-K-24	24	2
	VICTRIX KW	24	1	UNICAL			
	VICTRIX MAIOR	24	1		IDEA	24	1
	VICTRIX EXTRA	24	1		IDEA	28/32	1
ARISTON					ALCON 09	24	1
	GENUS CLAS	24/28	2		ALCON 09	28/35	1
	GENUS CLAS	35	2		KON-KONe	24/28	1
	EXT	25	1	KITURAMI			
	CARES/ HP	24	1		TWIN ALPHA	20/25	1
	EGIS PLUS	24	1		16D-DH		1
DEMIRDOKUM					25D-DH		1
	NITROMIX	24	1	BRAVA SLIM			
	NITROMIX	28	1		25HE		1
SATURN					30HE		1
	UNITEC	20/24	2		35HE		1
SIME				FOUDITAL			
	BRAVA ONE	24	1		CTN	24	1
	Όλα τα μοντελα		1		CTFS	24	1
BOSCH/JUNKERS					CTFS	28	1
	CONDENS 2000	24	1	ARCA			
	CONDENS 2500	24	2		PIXEL 25N	24,7	1
	GAZ 4000	24	1		PIXEL 25F	25,1	1
					PIXEL 25F	29,3	1

Multi-zone heating controller

- Ideal for 2-4 zones
- Compatible with: Radiators, Circulators, Magnetic Valves (and/or in combination)
- Controlled Heat Release Function
- Sturdy Metal Construction
- Indicator LEDs and Short-Circuit Safety
- Wiring Instructions Included

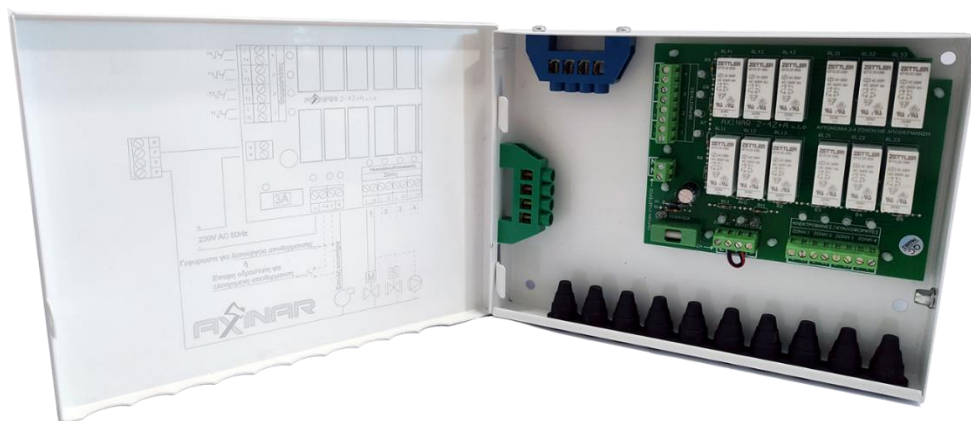

	2 zones	3 zones	4 zones
Dimensions (mm) WxDxH	230x30x170	230x30x170	230x30x170

SolBox

- Conversion of solar energy into electricity for water heating
- Operates with 2 photovoltaic panels on the roof.
- Competes with the solar water heater, does not require an additional solar boiler but utilizes the existing electric water heater of the house.
- Does not require demanding water installation from the roof to the house space.
- Does not require Inverter installation.
- Uses safe electricity current (low-voltage current 70V)
- Operation monitored via application, with statistics and potential faults reported to the company.
- Smart Schedule (weekly program for achieving water temperature utilizing external heat source/holiday & vacation scheduling)



Dimensions (cm) WxDxH	14,5x9,5x14,5
-----------------------------	---------------

THERMOSTAT

AXISTAT

- Large, clear display
- 100% reliable operation with all battery types
- Accurate battery replacement warning
- Built-in battery voltmeter
- Easy installation
- Temperature measurement in Celsius only
- User-friendly operation with only 3 buttons

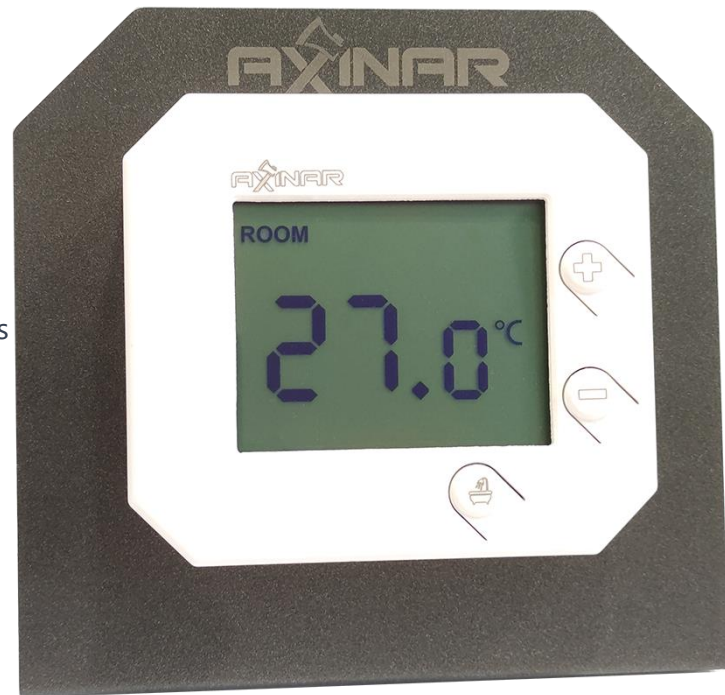

Operation:

- Domestic Hot Water (DHW) or cooling capability.
- Independent DHW option.
- Anti-freezing function.
- Intelligent adaptation to space targeted temperature.

	DOMESTIC	DOMESTIC WITH INDEPENDENT DHW	HOTEL UNITS
Dimensions (mm) WxDxH	110x20x95	110x20x95	110x20x95



Bi. Pa. Oraiokastrou 1055 | 57013

Thessaloniki, Greece | +30 2310 808159

www.axinar.com | sales@axinar.com

Your Axinar partner:



Website



Sales Contact